

- > RAINSTAR A
- > RAINSTAR T
- > RAINSTAR E



IRRIGATION

RAINSTAR A

THE MULTI-TALENTED PRO FOR A WIDE VARIETY OF APPLICATIONS



RAINSTAR A2

The compact series in a modern design

Standard delivery:

- RAINSTAR A1 with BAUER specific PE-pipe
- Hot-galvanized pipe reel and chassis
- Two-wheel gun-trolley with wide-profile tyres and integrated leg supports
- Drive system is BAUER full-flow turbine TCN 10
- 3 Speed adjustable V-belt transmission
- Mechanical speed regulator with automatic pipe layering compensator
- BAUER Speed-change gearbox with PTO winding system
- Power transmission is via precision chain drive
- Automatic gun-trolley lift
- Automatic final shut-off device
- Single axle chassis with universal variable track width

Easy handling, optimal output and innovative technology make the new A-Series irrigation machines from BAUER ideal for a wide variety of applications such as Sports facilities, parkland, schools, golf courses, garden centers, cemeteries, etc.

The same philosophy of quality, technology, and precision applied to our larger Rainstar units used in agriculture can also be found in the A-Series models.

Highest value due to an extraordinary price-performance ratio, best irrigation efficiency and wide range of applications.

Quick and easy swiveling of the reel into its required working position is easily done by only one person due to a 3-wheel chassis and automatic gun trolley lift.

RAINSTAR
A2



Powerful, compact
BAUER turbine/gear box
combination for RAINSTAR
A2 with precise adjustment
and exchangeable nozzles
for high efficiency.

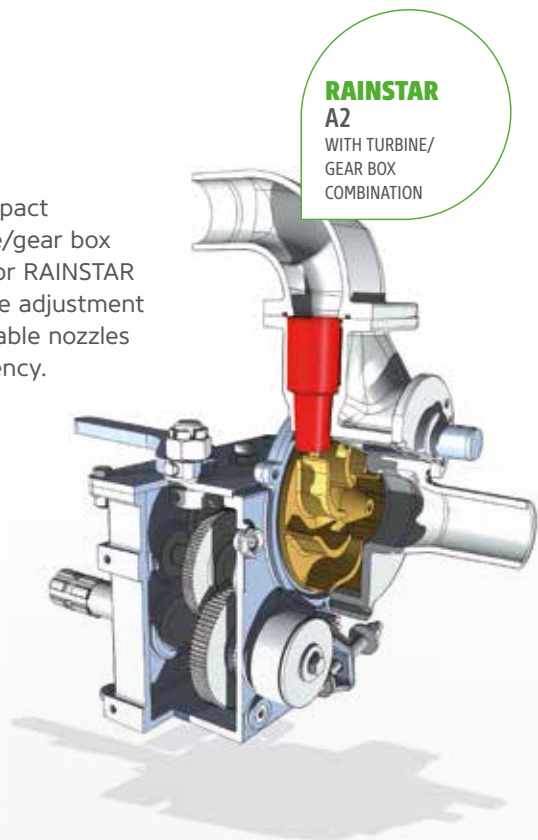

**RAINSTAR
A2**
WITH TURBINE/
GEAR BOX
COMBINATION



RAINSTAR A3

Largest model in the A-Series is a true Irrigation Specialist

Pro-gardening, Parkland, horticulture, golf courses, sports facilities and model farms – the RAINSTAR A3 multi-tasks in most applications – a smart choice for irrigation.

- RAINSTAR A3 with BAUER specific PE-pipe, Hot-galvanized pipe reel, turntable and chassis
- Two-wheel gun-trolley with wide-profile tyres. Adapts easily to any crop row spacing. The chassis has a rotating pipe reel and integrated leg supports
- Drive system is BAUER full-flow turbine
- 3 Speed adjustable V-belt transmission
- Mechanical speed regulator with automatic pipe layering compensator
- Speed-change gearbox with PTO winding system
- Power transmission is via precision chain drive
- Automatic gun-trolley lift
- Automatic final shut-off device
- PE-pipe rewind system with precision rewind shaft and strong support chassis
- Single axle chassis with universal variable track width ranging from 1000 – 1500 mm



Compact Drive Unit

The compact drive unit includes the BAUER full-flow turbine, the V-belt transmission and speed change gearbox.

This unit offers the optimum in economy and operating efficiency. Power transmission to the pipe reel is via a strong high-quality chain and precision laser-cut toothed gear elements. This optimised design offers extremely low pressure loss and high efficiency power output.

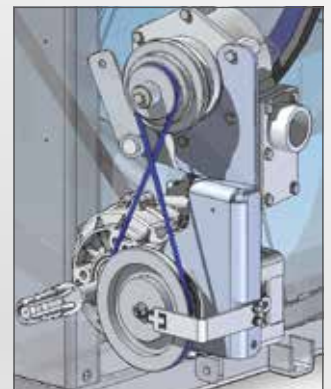



Convincing arguments for successful irrigation



Booster pump (optional)

With additional tank for approx. 12 hours of operation. Powered by Honda engine – directly mounted on the turntable.

Use scheme

To swivel the RAINSTAR A3 reel to the required working position is simple and easily undertaken by one person. Gives high operating efficiency maximising working hours. From a single position, irrigation can be undertaken in two directions.



Gun trolley

Automatic gun trolley lift at the end of irrigation strip – simple adjustment of the track width – for rain guns as well as for boom carts (A3).

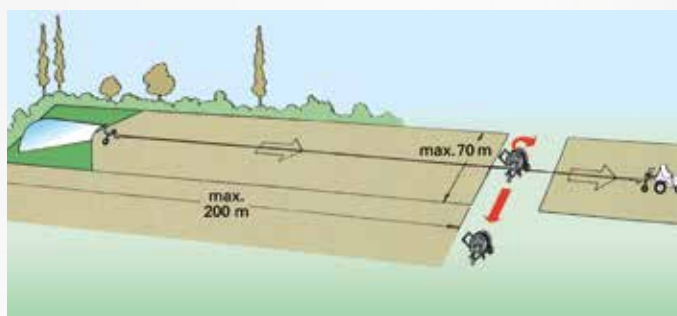

TECHNICAL DATA

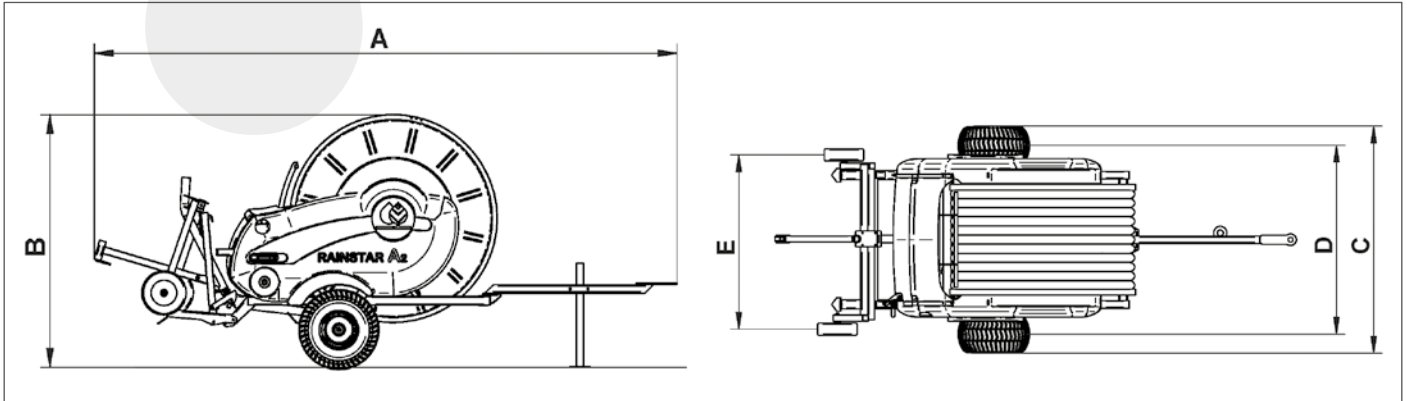

Specification

RAINSTAR Model	Type	PE pipe Ø mm	PE pipe length m	Strip width m	Consumption m ³ /h	Nozzle sizes mm	Connection press bar	Weight kg	
								with water	less water
A2	50 - 135	50	135	28 - 54	3,2 - 13	7 - 14	3,2 - 8	526	341
	55 - 120	55	120	30 - 58	4,0 - 16	8 - 16	3,2 - 8	546	351
	58 - 115	58	115	32 - 62	5,0 - 20	9 - 16	3,2 - 8	568	353
A3	55 - 170	55	170	38 - 57	7,5 - 18	10 - 16	4,0 - 8	792	515
	63 - 125	63	125	38 - 62	7,5 - 20	10 - 16	4,0 - 8	778	512
	63 - 150	63	150	38 - 62	7,5 - 20	10 - 16	4,0 - 8	855	537

Dimensions

RAINSTAR Model	A mm	B mm	C mm	D mm	E mm
A2	3.420	1.480	1.490	1.240	1.000 - 1.500
A3	3.550	1.690	1.730	1.250	1.000 - 1.500

Optional Equipment RAINSTAR A

- Automatic over-pressure shut-off valve
- Speedometer
- Connecting hose
- Boom trolley AS 16 with strip width of 32 m (A3)
- BAUER wide range sprinkler
- Booster pump directly mounted on the turntable

Three RAINSTAR A types

The RAINSTAR A models are available with the long durable BAUER PE pipe in length from 120 – 170 m. Options are pipe diameters from 40 – 63 mm.





PRODUCTS FROM OUR IRRIGATION PROGRAM



SYSTEM 9000



RAINSTAR



Your dealer

Röhren- und Pumpenwerk BAUER GmbH

8570 Voitsberg/Austria

T +43 3142 200-0

F +43 3142 200-320/-340

M sales@bauer-at.com

W www.bauer-at.com

